

ASSEMBLY AND ADJUSTMENT INSTRUCTIONS FOR DRESSMAKING MODELS



Adjusters/fittings may vary on some models

WWW.PASPOP.COM

Further information from www.adjustoform.com

As an ongoing policy of development we reserve the right to make product changes and improvements without notice.

Manufactured in England by Adjustoform Products Limited

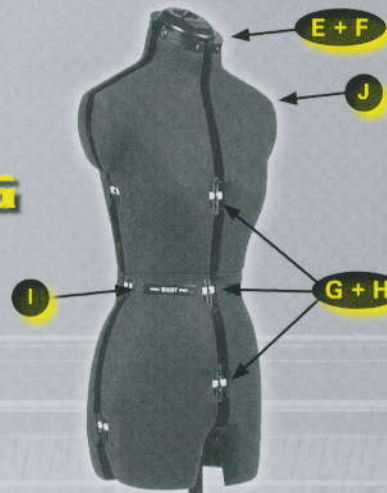

THIS BOX CONTAINS:

- torso
- feet
- post
- plastic bag

- (E) Refer to pictures for code
- (D) Kijk naar de plaatjes voor de nummers
- (F) Se referrer aux photos pour le code
- (G) Auf die abbildungen bezichen
- (S) Vea las shafenes

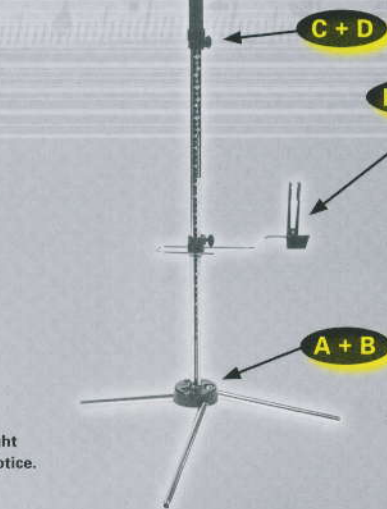

- (E) Keep plastic bags away from children
- (D) Houdt plastic zakken weg bij kinderen!
- (F) Laisser la housse plastique hors de la portee des enfants
- (G) Die plastiktueete von kindern fernhalten
- (S) mantega la bolsas de plastica alejadas de los ninos

Key: (E) English, (D) Dutch, (F) French, (G) German, (S) Spanish

ASSEMBLING FEET TO POST

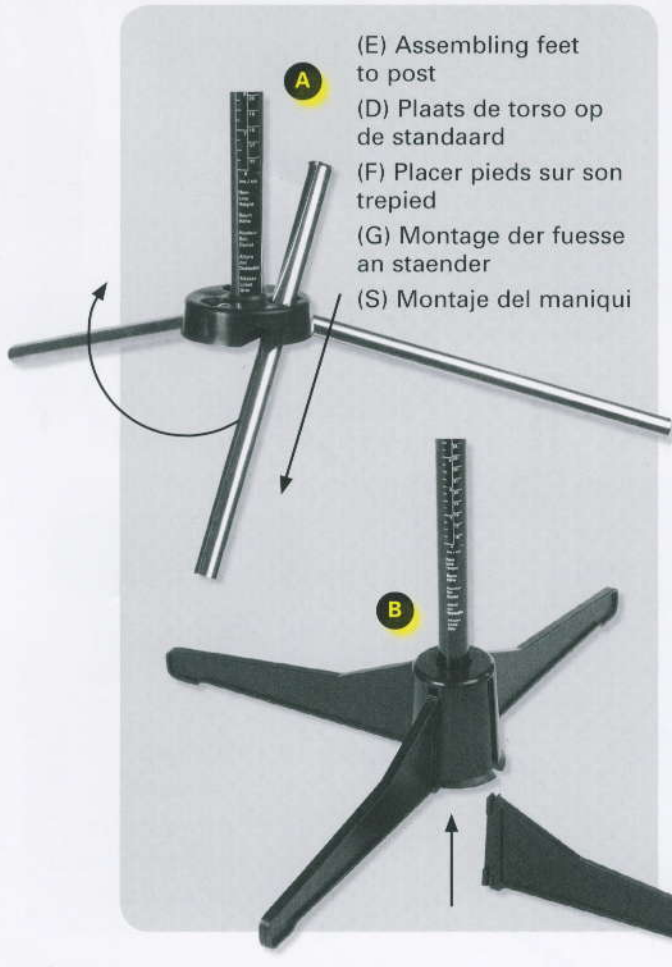

- (E) Assembling feet to post
- (D) Plaats de torso op de standaard
- (F) Placer pieds sur son trepied
- (G) Montage der fuesse an staender
- (S) Montaje del maniqui

ASSEMBLING BODY TO POST



Leg Form Only

- (E) Assembling body to post
- (D) Monteer de voeten aan de standaard
- (F) Placer le corps sur son trepied
- (G) Montage des koepers an staender
- (S) Montaje torso en barra

NECK AND BODY ADJUSTERS

- (E) Press down and turn
- (D) Druk in en draai
- (F) Appuyer et tourner
- (G) Niederdruecken und drehen
- (S) Presione y gire

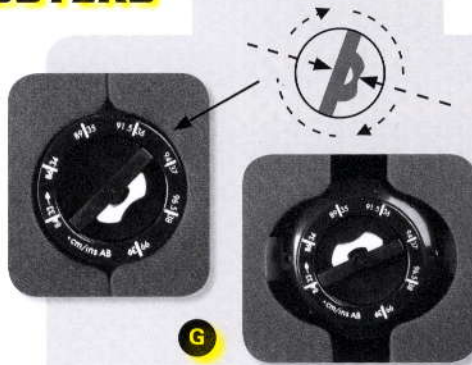
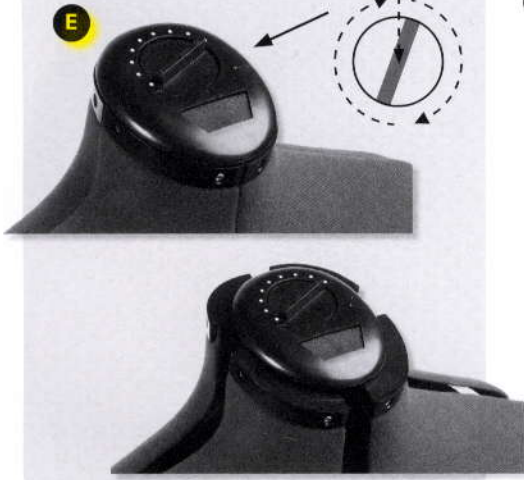

- (E) Press together and turn
- (D) Draai de knop
- (F) Presser ensemble et tourner
- (G) Zusamendruecken und drehen
- (S) Presione a la vee y gire

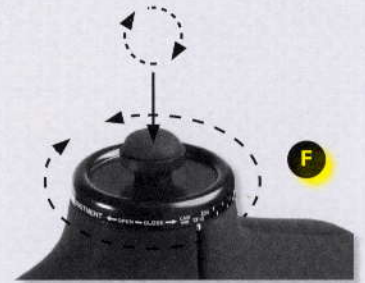

- (E) Turn to open and set
- (D) Draai om te openen en in te stellen
- (F) Tourner pour ouvrir et regler
- (G) Drehen zum oeffnen und einstellen
- (S) Gire para abrir y pijar



ADJUSTING WAIST LENGTH

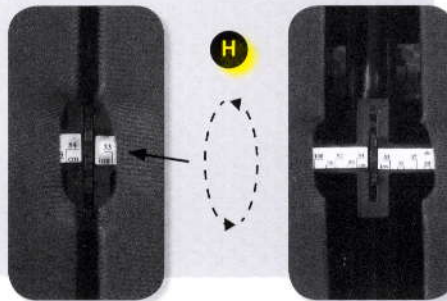

- (E) Rotate to open
- (D) Draai om te openen
- (F) Faire tourner pour ouvrir
- (G) Oeffnen durch drehen
- (S) Gire para abrir

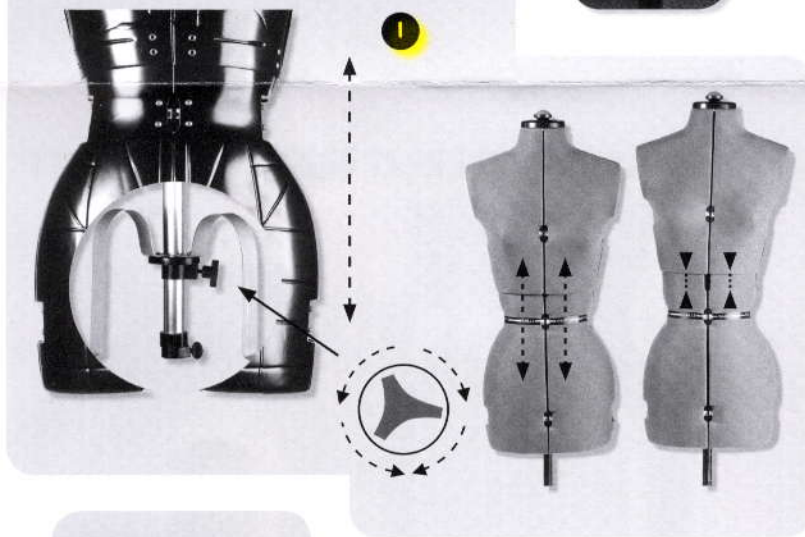

ADJUSTING HEIGHT

- (E) Stand next to dressmaking model
- (D) Ga naast uw paspop staan
- (F) Rester a cote du mannequin
- (G) Dicht an den schneiderbüste
- (S) Situese al lado del maniqui

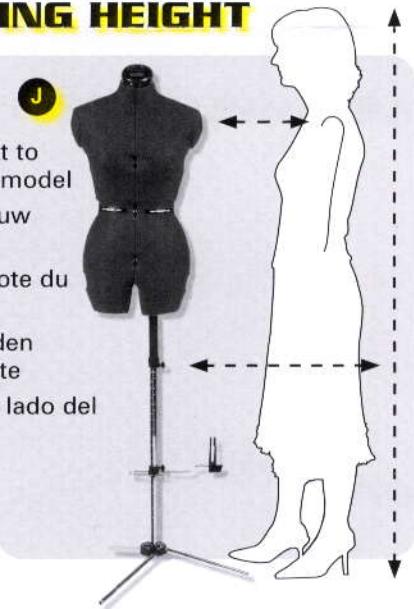

HEM MARKERS VARY BY MODEL

- (E) White chalk mark
- (D) Witte kalk markering
- (F) Craie de marquage blanche
- (G) Weisse krei de-markierung
- (S) Marca de tiza blanca

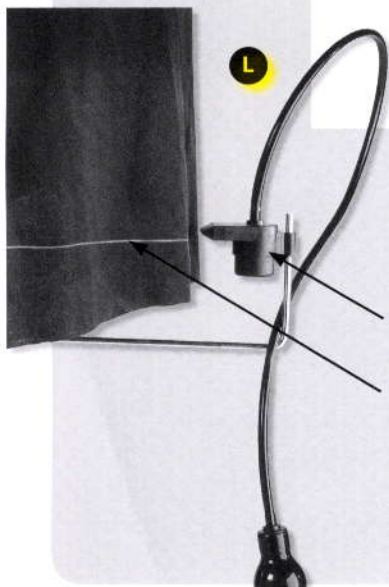

- (E) Hem leveller
- (D) Zoommeter
- (F) L'arrondissuer
- (G) Gebrauch Ihres Saumlängenbügels
- (S) Nivelador de dobladillo

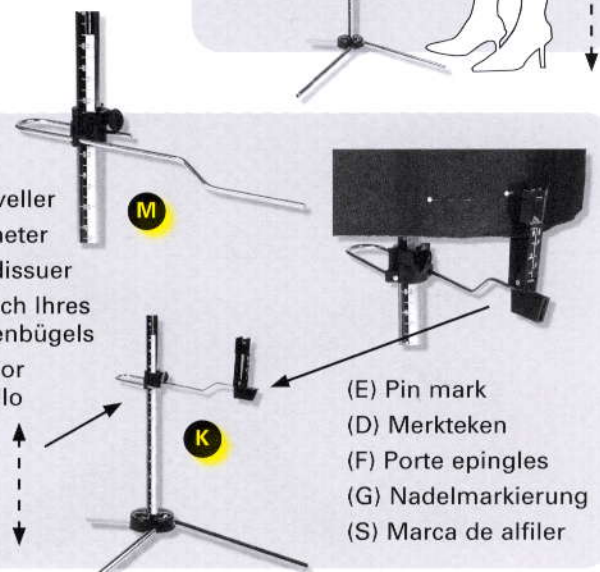

- (E) Pin mark
- (D) Merkteken
- (F) Porte epingles
- (G) Nadelmarkierung
- (S) Marca de alfiler